

# ELECTRIC PUMP EL604S

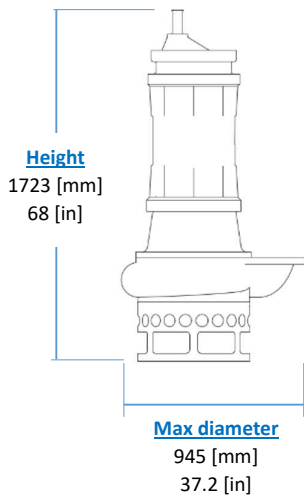
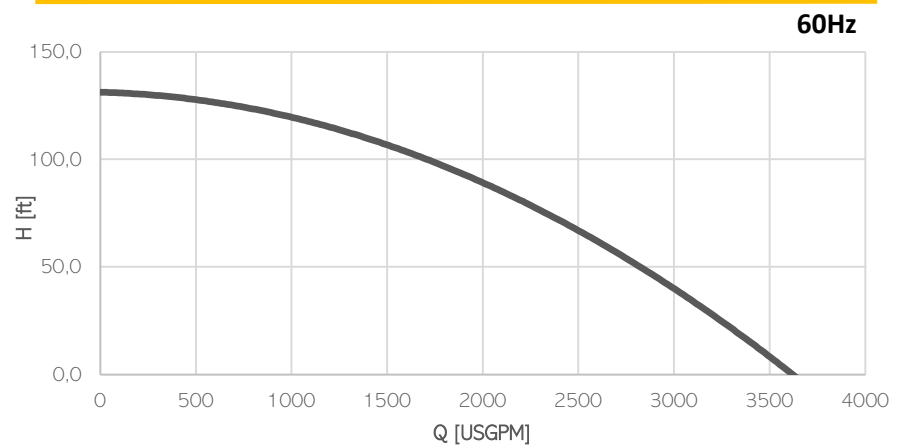
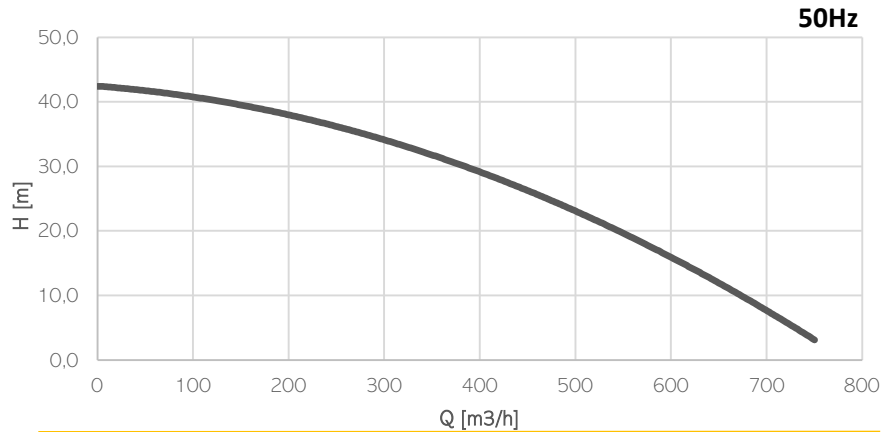

**KG**  
**Weight**  
(without cable)  
1115 [kg]  
2460 [lb]

### Electrical motor

Insulation class H

### Cable

1 x H07RN-F 4G50 length 20m

### Operating Conditions

- Max liquid temperature 35°C
- Min Submersion depth 1510 mm

Model	EL604S	
Brake Power [kW HP]	90   120	
Electric Power [kW HP]	96   128	
Frequency [Hz]	50	60
Efficiency [%]	54%	45%
Number of Poles	4	4
RPM	1480	1776
Voltage [V]	400	460
Rated Current [A]	158	141
Solid handling [mm in]	60   2.4	
Discharge [DN-PN]	150-10	

### Materials

Part	Standard
Casing	Cast Iron EN-GJS800
Body	Cast Iron EN-GIL250
Wear Parts	High chrome EN-GJN-HV600 (CH6)
Minimum hardness [HB]	550
Main shaft	High tensile 39NiCrMo3
PH Range	5-10

### Seals and lubricants

Version	EL604S	MG	MS
Motor Side	LIPS	MECHANICAL	MECHANICAL
Impeller Side	LIPS	LIPS	MECHANICAL
Oil type	EP320	ISO32	ISO32